



GOSHU KOHSAN CO., LTD.
www.goshukohsan.com

Degassing Membrane Unit : LC Type

“High Efficiency of Gas Removal with Cost Effective Degassing Membrane Unit”

Introduction

The degassing membrane unit uses an innovative technology for removing the gases from liquid or adding them to liquid by altering the concentration and pressure of the gases in contact with the water. We offer the excellent efficiency of the degassing membrane unit to meet a variety of applications of degassing, debubbling, decarbonation and deoxygenation as well as carbonation and nitrogenation in the microelectronics, pharmaceuticals, power, food & beverage, and other manufacturing processes.



Features

- ✦ Higher efficiency of gas removal than vacuum towers and forced draft degasifier with ppb level
- ✦ Small and compact unit with economical cost
- ✦ No chemical needed to operate
- ✦ Easy for scale-up with multiple membrane contactors
- ✦ Reduce sizing of transfer pump due to low pressure drop in membrane contactor
- ✦ Available in series configuration for greater gas removal efficiency or parallel configuration for increased flow rate

Applications

1. Removal of dissolved oxygen in electronics industry at point of use
2. Removal of bulk oxygen and nitrogen in the make-up and polishing loop systems
3. Removal of dissolved oxygen formed from ozone destruction
4. Removal of dissolved oxygen from process water in storage tank of power plant
5. Removal of carbon dioxide to extend the life of ion exchange beds
6. Removal of carbon dioxide to improve performance of EDI system
7. Accurate total control of dissolved gases at point of use
8. Removal of THM (Trihalogenated Methane) and other volatile compounds from water
9. Removal of bubble from aqueous streams in analytical measurements and other industrial processes
10. Carbonation, decarbonation and nitrogenation in the beverage industry
11. Others

Degassing Membrane Unit : LC Type

Principle

For removal of dissolved gases from an aqueous stream, membrane contactors are operated with the aqueous fluid flowing on one side of a hydrophobic membrane and a sweep gas and/or a vacuum applied to the other side of the membrane. Since the microporous membrane is hydrophobic, it will not allow aqueous fluid to pass through the pore whereas it allows dissolved gases selectively pass through the pore.

Flow Diagram

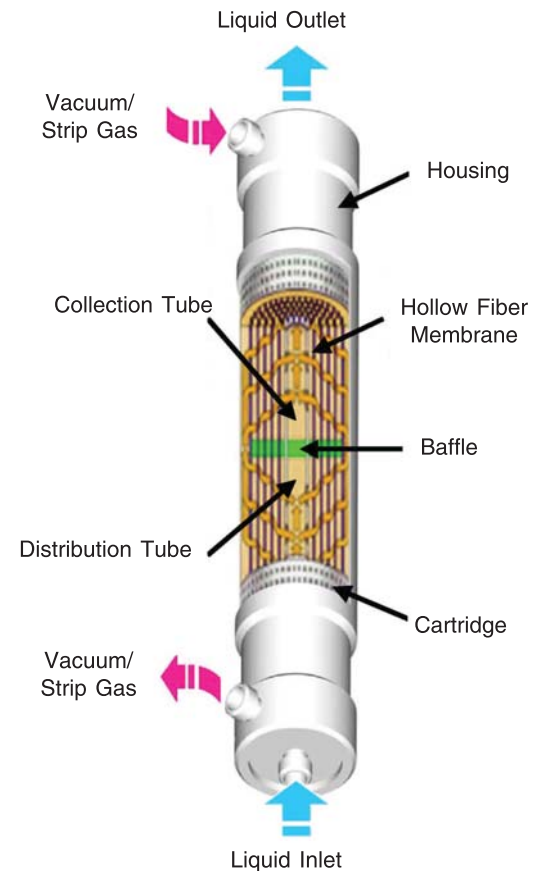
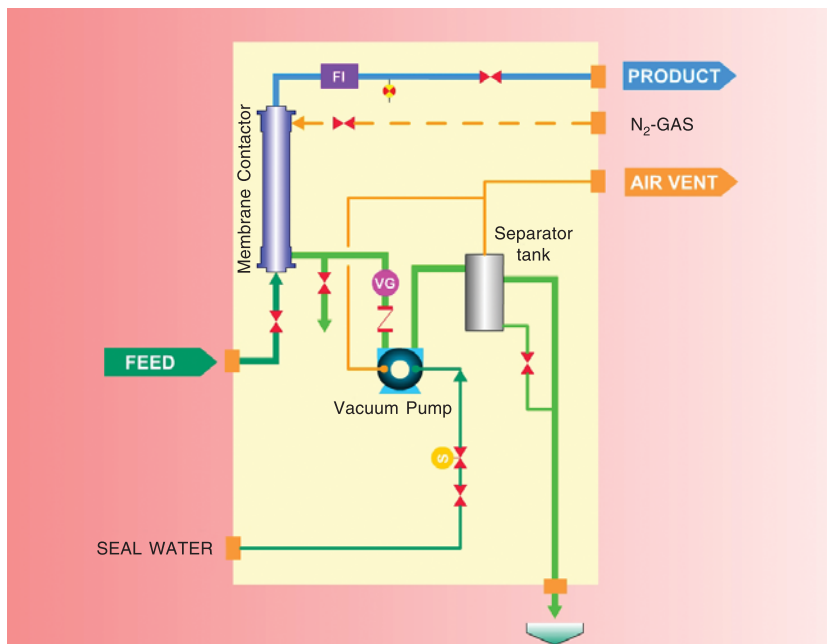

Specification List

| Model | Service Flow (m ³ /Hr) | Module Size (inches) | Membrane Material | Housing Material | Power Consumption (kW) | Unit Dimension (W x D x H) (mm) | Weight | |
|---------|-----------------------------------|------------------------|-------------------|-----------------------|------------------------|---------------------------------|--------------|----------------|
| | | | | | | | Product (Kg) | Operating (Kg) |
| LC-250 | 0.1 – 0.7 | ø 2.5 x 8 ^L | PP | PP | 150 | 550 x 775 x 1550 | 100 | 130 |
| LC-400 | 1.1 – 6.8 | ø 4 x 28 ^L | PP | PP or 316L SS or PVDF | 360 | 600 x 875 x 1625 | 130 | 170 |
| LC-1000 | 10 – 68 | ø 10 x 28 ^L | PP | FRP or 316L SS | 470 | 1000 x 1000 x 1800 | 220 | 260 |

Remark : Out of Scope ➡ Feed pump, Nitrogen gas

- The number of used membrane contactor and configuration type depends on flow rate, guarantee level and application.
- Wide range of products besides above items are available.
- All designs and specifications will be subject to change with or without prior notice.